

ETS

- Zones 1, 2, 21, 22
- Ex d protection
- Max. 114 dB



*Support bracket
mounting*

*Painted aluminium
body*

*Chrome coloured ABS
plastic protection*



ETS series Rotating electromechanical siren

ETS electromechanical sirens are used in potentially explosive environments such as oil refineries and chemical and petrochemical plants or in areas where flammable dusts or substances are present. Given the high level of sound they emit, they are used outdoors in industrial environments where there is significant background noise. They are used for different applications such as fire alarms, safety alarms, for emergencies and to signal plant evacuation and intrusion.

Application sectors:



CERTIFICATION DATA

Classification:	Group	Category 2GD		
Installation: EN 60079.14	zone 1 - zone 2 (Gas)	zone 21 - zone 22 (Dust)		
Marking:	CE Ex II 2 GD Ex d IIC T6 Ex tD A21 IP65			
Certification:	ATEX INERIS 02 ATEX 0001			
	TR CU AVAILABLE	All TR CU certification data can be downloaded at www.cortemgroup.com		
Standards:	CENELEC EN 60079-0: 2006, EN 60079-1: 2004, EN 61241-0: 2006, EN 61241-1: 2004 and EUROPEAN DIRECTIVE 2014/34/UE			
Class temperature:	85°C (T6)			
Ambient temperature:	-20°C +40°C			
Degree of protection:	IP65			

ETS series Rotating electromechanical siren



MECHANICAL FEATURES

Body and cover:	Low copper content aluminium alloy
Protection:	Chrome coloured ABS plastic
Gasket:	Acid, hydrocarbon and high temperature resistant silicone
Bolts and screws:	Stainless steel
Mounting:	Direct to 3/4" entry or with mounting bracket (available on request)
Entries:	1 x 3/4" Rc UNI ISO 7/1
Coating:	Epoxy vinyl coating Ral 7000 (squirrel grey)

ELECTRICAL FEATURES

ETS60/109 signaller

Rated voltage:	Vac/dc $\pm 10\%$	12	24	48	110	230
Frequency:	Hz	50/60	50/60	50/60	50/60	50/60
Current:	A	10,6	6,1	3,4	1,1	0,6
Operation:	Intermittent					

ETS60/114 signaller

Rated voltage:	Vac/dc $\pm 10\%$	12	24	115	230
Frequency:	Hz	50/60	50/60	50/60	50/60
Current:	A	11,5	5,9	1,6	0,9
Operation:	Intermittent				

ACCESSORIES AVAILABLE / SPECIAL REQUESTS

Cable gland: FGAB2BK for armoured cable or FB2BK for non-armoured cable
Adjustable support bracket
Epoxy vinyl coating in different colours
NPT or ISO M25 threads
Different rated voltages

ETS series selection chart

Code	Intermittent operation	Voltage	Sound level		Weight kg	 mm
			Frequency	Db/m		
ETS60/109DB12V	2 Min. ON / 5 Min. OFF	12 V Ac/Dc	1150 Hz	109	2,8	230x140x140
ETS60/109DB24V	2 Min. ON / 5 Min. OFF	24 V Ac/Dc	1250 Hz	109	2,8	230x140x140
ETS60/109DB48V	2 Min. ON / 5 Min. OFF	48 V Ac/Dc	1300 Hz	109	2,8	230x140x140
ETS60/109DB115V	2 Min. ON / 5 Min. OFF	110 V Ac	1300 Hz	109	2,8	230x140x140
ETS60/109DB230V	2 Min. ON / 5 Min. OFF	230 V Ac	1300 Hz	109	2,8	230x140x140
ETS60/114DB12V	2 Min. ON / 5 Min. OFF	12 V Ac/Dc	650 Hz	114	3,4	260x140x140
ETS60/114DB24V	2 Min. ON / 5 Min. OFF	24 V Ac/Dc	650 Hz	114	3,4	260x140x140
ETS60/114DB115V	2 Min. ON / 5 Min. OFF	115 V Ac	650 Hz	114	3,4	260x140x140
ETS60/114DB230V	2 Min. ON / 5 Min. OFF	230 V Ac	650 Hz	114	3,4	260x140x140

DIMENSIONAL DRAWINGS

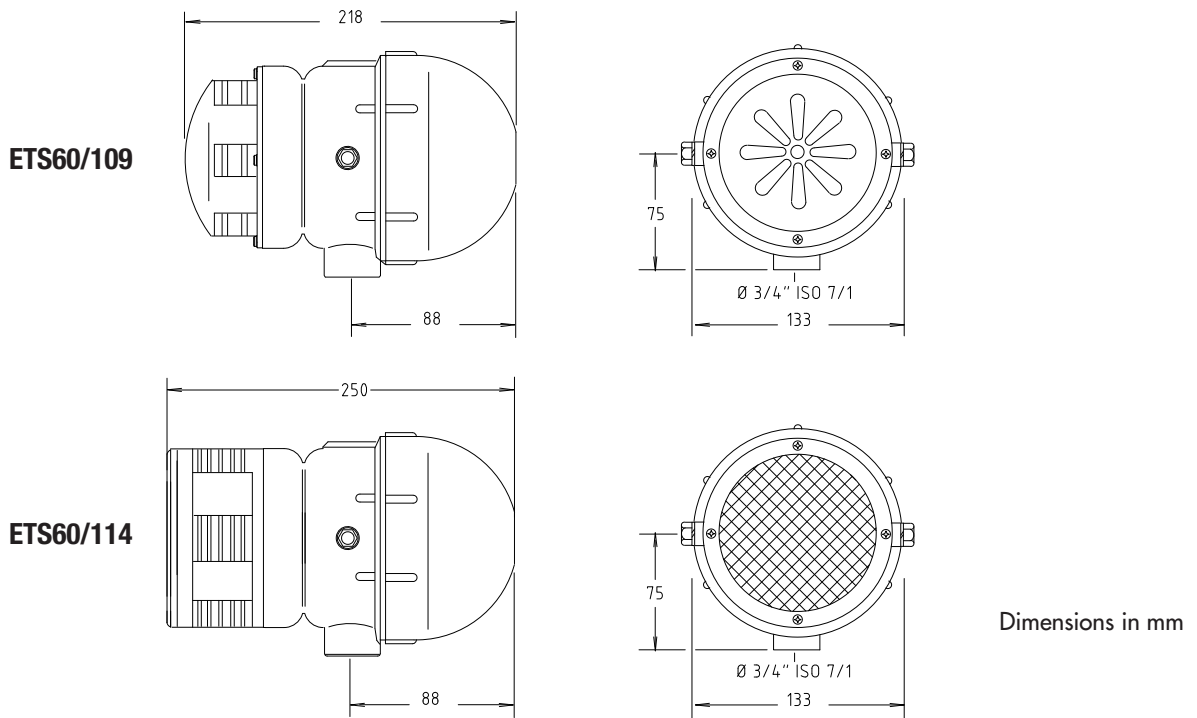
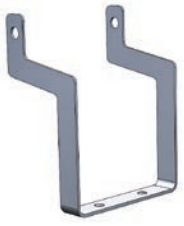





ILLUSTRATION	DESCRIPTION	FEATURES	CODE	KEY
	Adjustable support bracket	Material: galvanised steel	K-340	 
			K-340/1	
	Cable gland	For cable gland models and codes see www.cortemgroup.com	FGAB2BK FB2BK	